

# **Light Meter (Lux)**

840006

## **Instruction Manual**

## TABLE OF CONTENTS

1. INTRODUCTION.....	2
2. PANEL DESCRIPTION.....	2
3. MEASUREMENT PROCEDURES.....	3
4. ZERO ADJUSTMENT & CALIBRATION.....	3
5. BATTERY REPLACEMENT .....	4
6. SPECIFICATIONS.....	4
7. LIGHT SPECTRUM CHART .....	4
8. WARRANTY.....	4

### 1. INTRODUCTION

Compact and portable, your new meter can be used to monitor light levels or check the LUX level of a particular light source. The sensor's exclusive photo diode and color correction filter meets the C.I.E. photopic spectrum with a cosine correction factor meets the standard. Sper Scientific light meters are cosine corrected for a quick and accurate response. Large easily legible LCD. The meter has an external zero adjustment, data hold, low-battery indicator, and a moisture resistant front panel. Comes with soft carrying case, detachable light sensor, photo-sensor cover, instructions and a 9-Volt battery.

### 2. PANEL DESCRIPTION

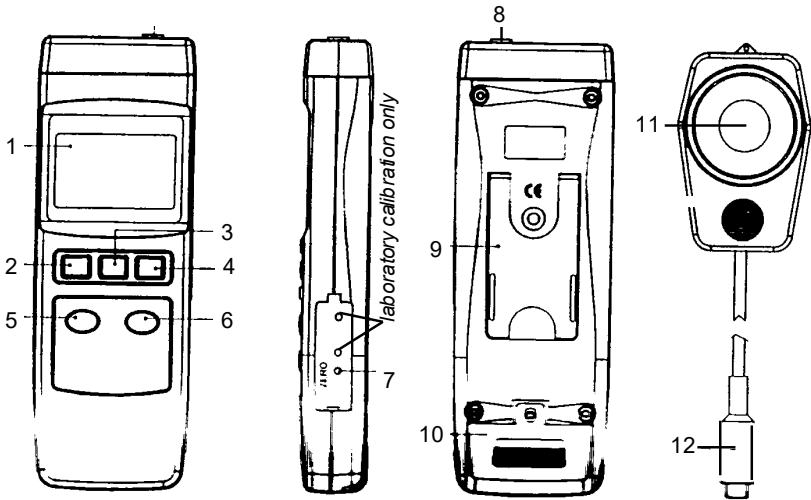

1. DISPLAY	5. X1 (2,000 RANGE) button	9. STAND
2. ON button	6. X10 (20,000 RANGE) button	10. BATTERY
3. OFF button	7. ZERO SETTING terminal	11. PHOTO SENSOR
4. HOLD button	8. SENSOR INPUT socket	12. SENSOR plug

### 3. MEASUREMENT PROCEDURES

- Insert the **SENSOR** plug into the **SENSOR INPUT** socket.
- Turn the meter on using the **ON** button.
- Remove the lens cap from the **PHOTO SENSOR**.
- Press the **1X** button for measurements of 0 to 1999 LUX, or select the **10X** button for measurements of 2,000 to 19,990 LUX. If you are uncertain about which range to use, select the highest range. In 10X mode, “ ▽ ” appears in the right bottom LCD.
- Range Overload is indicated when “1” appears on the left side of the display. If this occurs, switch to the highest range or discontinue use.
- Point the **PHOTO SENSOR** toward the source and read the results on the display. To convert LUX results to FC, multiply the meter reading by the factor of .0929
- Push the **HOLD** button to freeze the reading in the display. The word “HOLD” is displayed. Press the **HOLD** button again to exit this function.
- Press the **OFF** button to turn the unit off.

#### NOTES:

- Keep the lens cap on the PHOTO SENSOR at all times except when actually taking a reading.
- Fluctuations in the reading are generally due to shadows or fluctuations in the line voltage. Ambient temperature, drafts and ventilation also affect the luminous flux output.
- Avoid range overload and do not store in areas of high temperature and/or humidity. Remove the battery for long-term storage.

### 4. ZERO ADJUSTMENT & CALIBRATION

**WARNING: Only use the terminal marked "ZERO" for adjustment.**

The unmarked terminals are for professional laboratory calibration only and tampering with these terminals will result in inaccurate readings and require professional calibration of the meter.

- With the sensor cover securely in place and the meter turned on, the LCD display should indicate “0000”. A slight variation will not affect readings; however, if a precise reading is required you may use the **ZERO SETTING** terminal to reset the unit.
  - To make an adjustment, cover the **PHOTO SENSOR** and press the **1X** button.
  - Use a small screwdriver to turn the **ZERO SETTING** terminal until “0000” is displayed.
  - To maintain accuracy, annual laboratory calibration is recommended.

## 5. BATTERY REPLACEMENT



Replace the battery when the low battery icon is displayed in the left corner of LCD. In-spec measurements may be made for several hours after the low battery indicator appears. Remove the battery compartment screw and slide the cover away from the meter, remove the battery and replace with a 9V battery (alkaline or heavy duty type). Replace the cover.

## 6. SPECIFICATIONS

Display	Maximum reading 19,990	
Overload Indicator	"1" is displayed on the left of the LCD	
Range*	2,000 Range = 0 to 1,999 LUX 20,000 Range = 2,000 to 19,990 LUX	
Resolution*	2,000 Range = 1 LUX 20,000 Range = 10 LUX	
Accuracy*	±5% + 4 digits	
Operating Environment	32 to 122°F (0 to 50°C), less than 80% RH	
Weight	9.9 oz (280g)	
Dimensions	Main Unit: 7.9 x 2.7 x 1.2" (200 x 68 x 30mm) Photo Sensor: 3.2 x 2.2 x 0.3" (82 x 55 x 7mm) Photo Sensor Lead: Extends to appx. 3½ ft	
Optional Accessories	840090 - Water Resistant Instrument Pouch 840093 Field Tripod	
*Electronic Specifications (23 ± 5°C): Tested under the environment RF Field Strength less than 3 V/M, and frequency less than the 30 MHz only.		

## 7. LIGHT SPECTRUM CHART 8. WARRANTY

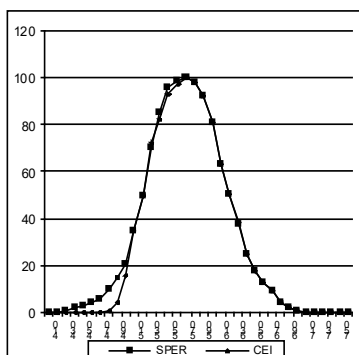

Sper Scientific warrants this product against defects in materials and workmanship for a period of **five (5) years** from the date of purchase, and agrees to repair or replace any defective unit without charge. If your model has since been discontinued, an equivalent Sper Scientific product will be substituted if available. This warranty does not cover probes, batteries, battery leakage, or damage resulting from accident, tampering, misuse, or abuse of the product. Opening the meter to expose its electronics will break the waterproof seal and void the

warranty. To obtain warranty service, ship the unit postage prepaid to:

**SPER SCIENTIFIC LTD., 8281 E. Evans Rd., Suite #103,  
Scottsdale, AZ 85260, (480) 948-4448**

The defective unit must be accompanied by a description of the problem and your return address. Register your product online at [www.sperwarranty.com](http://www.sperwarranty.com) within 10 days of purchase.