

**4 Channel  
Datalogging Thermometer**

800024

Instruction Manual

SPER  
SCIENTIFIC

---

Environmental Measurement Instruments

## TABLE OF CONTENTS

INTRODUCTION .....	3
FEATURES.....	4
MATERIALS SUPPLIED .....	4
FRONT PANEL DESCRIPTION.....	5
LCD DISPLAY .....	6
SET UP .....	7
MEASUREMENT PROCEDURES.....	12
SOFTWARE INSTALLATION.....	16
DATALOGGING .....	19
POWER SUPPLY.....	26
CARE AND MAINTENANCE.....	26
SPECIFICATIONS .....	27
WARRANTY .....	28

## **INTRODUCTION**

This Sper Scientific 4 Channel Datalogging Thermometer (Model 800024) displays data from four thermocouple probes simultaneously on a large backlit LCD. Up to 16,000 data records for each channel can be stored in the meter and saved, graphed and processed on a computer through the included USB interface and software. Real-time data can be logged both in the field and with the meter connected to a computer.

## **FEATURES**

- Four-channel simultaneous display
- Customizable High/Low Alarm (Channel 1)
- Maximum/minimum/average values
- Offset to compensate for probe errors
- T1 – T2  $\Delta$  delta mode
- 16,000 data points stored per channel
- Direct upload of data to EXCEL, text, or graph files.
- Customizable data graphing
- Adjustable Automatic shutoff
- Backlight
- Instant Recall Function

## **MATERIALS SUPPLIED**

- Datalogging Thermometer
- USB Cable
- Two K-type Beaded Wire Probes
- Software Disc
- Instruction Manual
- Four AAA batteries
- Carrying Case

# FRONT PANEL DESCRIPTION

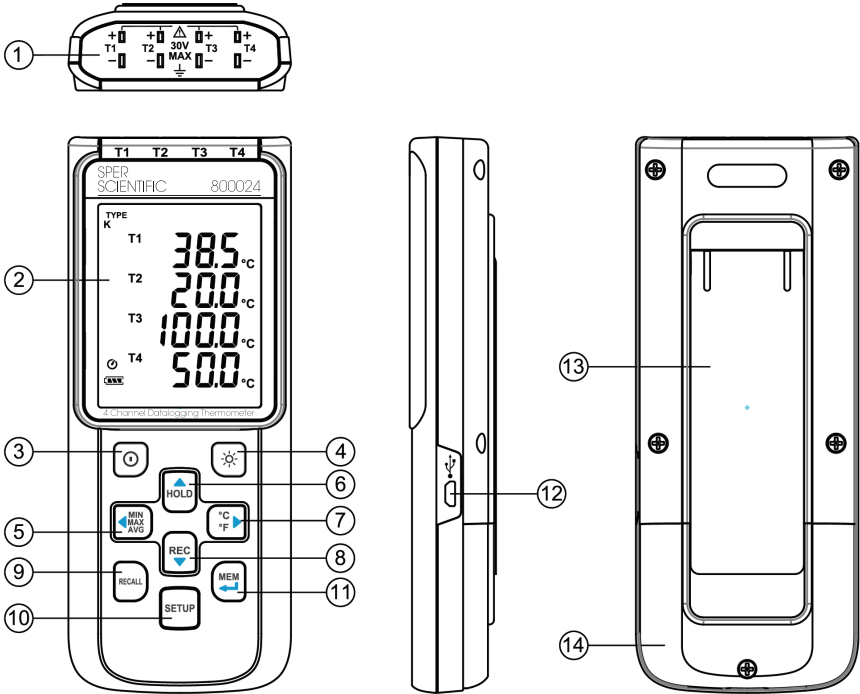

- 1. Thermocouple Input
- 2. LCD Display
- 3. Power Button
- 4. Backlight Button
- 5. Maximum/Minimum/Average Button
- 6. Data Hold Button
- 7. Temperature Unit Selector

- 8. Record Button
- 9. Recall Button
- 10. Setup Button
- 11. Memory Button
- 12. USB Interface/Power Supply
- 13. Tilt Stand
- 14. Battery Compartment

# LCD DISPLAY

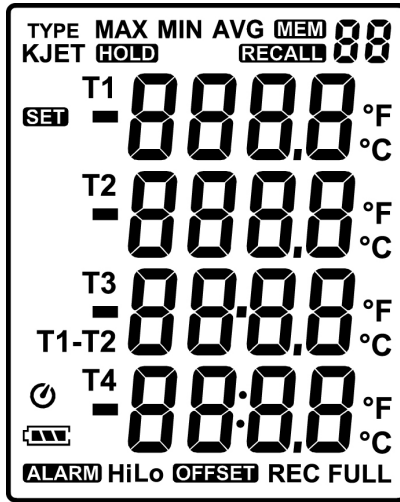

Low-Battery Icon

MIN

Minimum Reading

MAX

Maximum Reading

AVG

Average Reading

SET

Setup Mode



Automatic Shutoff Indicator

REC

Recording In Process

FULL

Memory Full Indicator

MEM 88

Save Reading In Memory

RECALL 88

Recall stored reading

TYPE KJET

Thermocouple type

-8888

Temperature reading

T1 T2 T3 T4

Temperature channel

T1 - T2

Δ Delta mode

ALARM

Alarm indicator

Hi

High temperature alarm

Lo

Low temperature alarm

OFFSET

Offset on to compensate for probe errors

°C °F

Temperature units

HOLD

Data hold indicator

## SETUP

### Meter On and Off

1. Press **POWER** to turn the meter **on**.
2. Press and hold **POWER** for 3 seconds to turn the meter **off**.

### Setup Mode

1. Press **POWER** to turn the meter **on**.
2. Press **SETUP** to enter Setup Mode.
3. Press **MEM** to cycle through the setup options.

### Note...

Press **SETUP** to exit Setup Mode. The meter will return to Normal Mode.

### Thermocouple Type

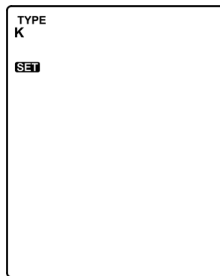

1. “Type” appears on the display along with the thermocouple type. Press ▲ or ▼ to cycle through K, J, E and T types.
2. Press **MEM** to save the selection.

## Time Interval



The time interval range for storing data is 1 seconds to 60 minutes 59 seconds.

1. "Int" appears on the display along with the time interval in minutes and seconds. The minutes flash on the display.
2. Press ▲ or ▼ to adjust the minutes.
3. Press ◀ or ▶. To move from seconds to minutes.
4. Press ▲ or ▼ to adjust the seconds.
5. Press **MEM** to save the selection.

## Offset Values

Thermometer readings can be adjusted to compensate for probe errors. The offset range is  $\pm 5$  °C or  $\pm 9$  °F.

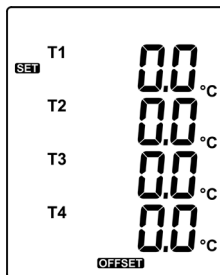

1. "T1" through "T4" appear on the display. Press ◀ or ▶ to cycle through the thermocouple channels.
2. Press ▲ or ▼ to increase or decrease the offset value.
3. Press **MEM** to save the selection.

## Alarm

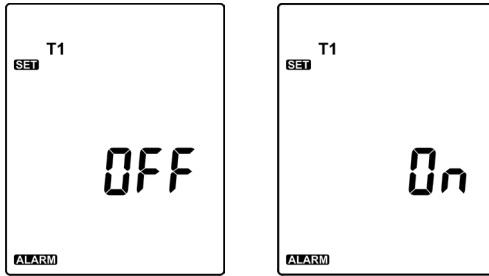

High and low alarm values can be set for channel T1.

1. “OFF” or “On” flashes on the display. Press ▲ or ▼ to toggle between alarm **off** and **on**.
2. With the alarm **on**, press **MEM** to set the alarm thresholds.

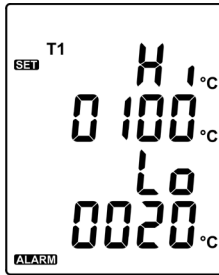

3. The first digit of the high alarm threshold flashes. Press ▲ or ▼ to increase or decrease the value.
4. Press ► to select the next digit.
5. Press ▲ or ▼ to increase or decrease the value.
6. Repeat steps 4-5 to set both the high and low alarm threshold values. Press ◀ if needed to return to a previous digit.
7. Press **MEM** to save the selection.

## T1 - T2 Δ Delta Mode

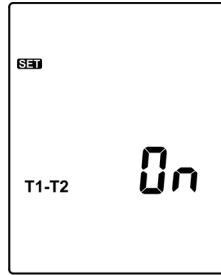

“OFF” or “On” flashes on the display. Press ▲ or ▼ to toggle between T1 - T2 Δ Delta Mode **off** and **on**.

## Automatic Shutoff

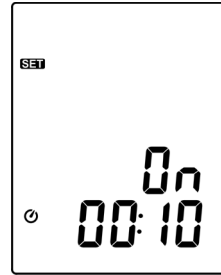

1. Press ▲ or ▼ to disable automatic shutoff or to select 10 or 30 minutes or 1, 2, 4, or 8 hours before automatic shutoff.
2. Press **MEM** to save the selection.

## Date and Time

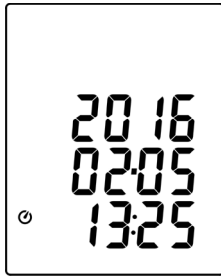

1. The date and time display and the year flashes. Press ▲ or ▼ to set the year.
2. Press ► to select the month. Press ◀ if needed to return to a previous selection.
3. Press ▲ or ▼ to set the month.
4. Press ► to select the day.
5. Press ▲ or ▼ to set the day.
6. Press ► to select the hour.
7. Press ▲ or ▼ to set the hour.
8. Press ► to select the minutes.
9. Press ▲ or ▼ to set the minutes.
10. Press **MEM** to save the selection.

## MEASUREMENT PROCEDURES

1. Insert the thermocouple(s) into the appropriate port(s).
2. Press **POWER** to turn the meter **on**.

### Backlight

1. Press the backlight button to illuminate the LCD screen.
2. The backlight will shut off automatically after 30 seconds, or press the backlight button to turn it off sooner.

### Select Temperature Units

Press **°C °F** to toggle between Celsius and Fahrenheit temperature units.

### T1 - T2 $\Delta$ Delta mode

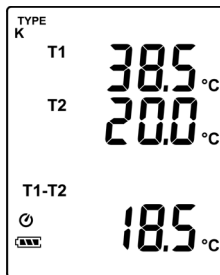

If T1 – T2  $\Delta$  Delta mode is selected the temperature difference displays on the lower right of the LCD.

## Data Hold

### Note...

The **MIN/MAX/AVG**, °C °F, **RECALL** and **SETUP** buttons on the meter are disabled during data hold.

1. Press **HOLD** to freeze the reading on the display. “Hold” appears at the top of the LCD.
2. Press **HOLD** to return to Normal Mode.

## Maximum/Minimum/Average Mode

### Note...

Viewing the maximum, minimum and average values will not interrupt temperature measurement. The maximum, minimum and average values will continue to be updated.

1. Press **MIN/MAX/AVG** to enter Maximum/Minimum Mode and record maximum, minimum and average values. “MAX” values are continually updated and displayed.
2. Press **MIN/MAX/AVG**. Minimum values are continually updated and displayed.
3. Press **MIN/MAX/AVG**. Average for the values are continually updated and displayed.
4. Press **MIN/MAX/AVG**. “MAX,” “MIN” and “AVG” blink. The meter displays real-time readings while continually updating its’ MIN/MAX/AVG records internally.
5. Press and hold **MIN/MAX/AVG** for 2 seconds to return to Normal Mode.

## Recording Data

### Note...

Most of the buttons on the meter are disabled during recording. All settings must be selected before recording begins.

1. Press **REC** to begin recording the readings. “REC” displays on the LCD. If 16,000 readings have been stored for a channel, “REC FULL” blinks on the LCD.
2. Press **REC** to stop recording.

### Note...

The meter will not record if battery power is extremely low.

### Note...

REC FULL stays on the display until the data is cleared. Computer can still access the data even though REC FULL is displayed.

## Clearing the Recorded Data

1. Press and hold **POWER** for 3 seconds to turn the meter **off**.
2. Press and hold **REC**.
3. While continuing to hold **REC**, press and hold **POWER** to turn the meter **on**.
4. Continue to hold **REC** and **POWER**. The meter displays “REC,” “Clr” and “SUrE 5” and counts down to zero.
5. To exit the process without clearing the memory, release the **REC** and **POWER** buttons before “SUrE 0” displays.

## Memory Function

### To save a reading:

1. Press **MEM** to save the reading on the display.
2. The “MEM 88” symbol lights up for 2 seconds to show the next number of the saved reading, from 00 to 99.

### To recall a reading:

1. Press **RECALL**. The “RECALL 88” symbol lights up on the display.
2. Use the **▲** or **▼** buttons to select a saved memory. The LCD shows the time of the reading for 2 seconds followed by the saved data.
3. Press **RECALL** to return to Normal Mode.

## Clearing Readings in Memory

1. Press and hold **POWER** for 3 seconds to turn the meter **off**.
2. Press and hold **MEM**.
3. While continuing to hold **MEM**, press and hold **POWER** to turn the meter **on**.
4. Continue to hold **MEM** and **POWER**. The meter displays “MEM,” “CLr” and “SUR 5” and counts down to zero.
5. “CLr 0” displays as the meter begins erasing records.
6. To exit the process without clearing the memory, release the **MEM** button before “SUR 0” displays.

# SOFTWARE INSTALLATION

<b>System Requirements</b>	Windows XP / VISTA / 7 / 8 / 10
<b>Minimum Hardware Requirements</b>	PC or laptop with CD-ROM ≥50 MB hard disk space to install SE800024 Screen resolution ≥ 1024 x 768

**Note...**

Different computer systems may require slightly different installation steps than those below.

1. The first most important step in software installation is to verify that the target system meets the general hardware requirements of the application. Beginning the installation in a computer which does not possess the minimum requirements can lead to either an unsuccessful installation or failure of the program to run after installing it.
2. Since programs in general are written to be Operating System dependent, make sure that the version of the application you are installing corresponds to the Operating System platform running on your machine.
3. Aside from the general hardware requirements, some computer programs also have software requirements prior to installation. Double check if you need to update or upgrade your Operating System or if there is a need to download other tools or utilities.

4. Once all the initial requirements have been met, make sure that there are no unnecessary programs running before beginning the installation procedure. In some instances, applications may require that the antivirus programs be disabled. Make sure that you are installing a legitimate application before disabling your protection software.
5. Software installation can be done either from the Internet (skip to step 8) or from an installation disc provided by the software manufacturer. To install from the disc, simply open the CD or DVD drive and insert the installer.
6. A setup wizard window should be launched. In case there is none, open the Explorer and navigate to the optical drive. Double click on either the Autorun or Setup file.
7. Once the wizard is running, simply follow the prompts until the installation process is completed. For novice users, accept the default values to minimize potential problems during the procedure. Jump to step 10.
8. For installation from the Web, launch your browser application, Go to: [www.sperdirect.com/software.htm](http://www.sperdirect.com/software.htm), find your meter, and download the setup file to your hard drive.
9. After completion of the downloading process, run the setup program to execute the setup wizard that will handle the automatic installation of the software. Do step 7.
10. After the installation procedure has been completed and the setup wizard has terminated, reboot your machine before launching the newly installed software.

## **Uninstalling the Software**

If you wish to remove SE800024 from your computer, the software may be uninstalled using one of the following methods. Note that your system may require slightly different steps.

1. Click on the Start Menu.
2. Select "Control Panel."
3. Launch the Add/Remove Programs.
4. Highlight "SE800024."
5. Click on "Add/Remove."
6. Click "Next."
7. Click "Next."
8. Click "Finish."

### **OR**

1. Click on the Start Menu.
2. Select "Control Panel."
3. Select "Programs and Features."
4. Double-click on "SE800024."
5. The Installation Dialog Box appears. Select "Uninstall" and click "Next."
6. Click "Next."
7. Click "Finish."

## DATALOGGING





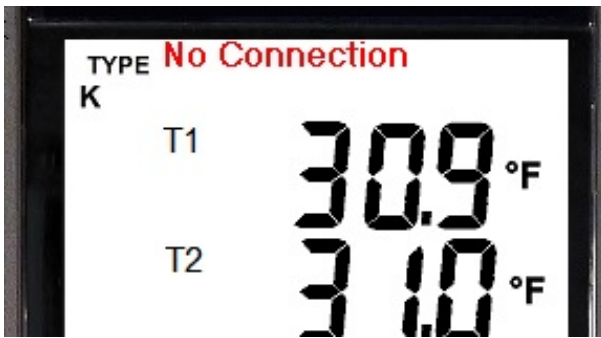

### Recording Real-Time Data in Graph Form

1. Press **POWER** to turn the meter on.
2. Insert the thermocouple(s) into the appropriate port(s).
3. Connect the meter to the PC using the USB cable provided.
4. Open the SE800024 program. An image of the meter displays along with a real-time graph.
5. The readings on the meter should display on the on-screen panel. If “No Connection” displays, re-connect the cable.



6. Click “Real Time” to begin recording real-time data.
7. Click “Run.” The Real-Time Setup Menu displays.
8. Enter the number of data points to record.
9. Enter the sampling rate.
10. Enter the recording period.
11. Click “Start” to begin recording and graphing.
12. Click to end recording.

## Tool Bar Options

	Hide or display the statistics above the graph (Statistic 1.)
	Hide or display the statistics below the graph (Statistic 2.)
	Restore normal cursor.
	Change cursor to an “X.” Click anywhere on the graph to mark it with an “X.” This option is not available when “Split” is selected.
	Change cursor to an “I.” Click anywhere on the graph to add an annotation. This option is not available when “Split” is selected.
	Set annotation color, ensuring sufficient contrast with the graph background.
<b>Split</b>	Separate or combine the four channels in the graph. When “Split” is not selected the graph will use T1 as the Y axis.



- Separate the four channel.

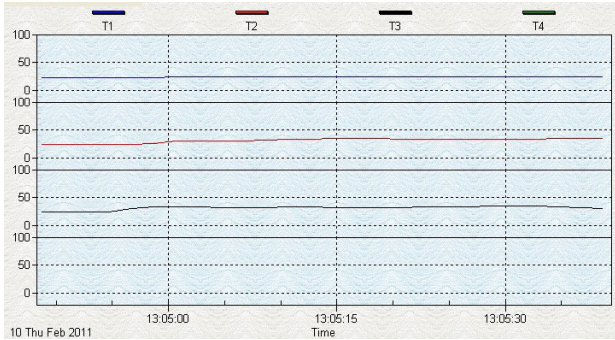

- Combine the four channel.

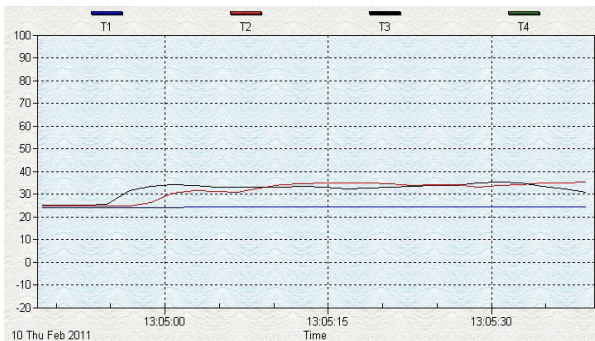

## Viewing the Graph

- **To zoom in:** Press the left mouse button and drag the cursor to select the new area.
- **To zoom out:** Click “Undo Zoom”

## Customizing the Graph

1. Click “Graph Option” to open the Customization Menu. This allows you to specify the channel displayed, modify the graph style, add a title and subtitle, maximize the graph and export the graph to the clipboard, a file or a printer.

Graph Option - Graph Customization

Y Axis - Change the Y axis extension

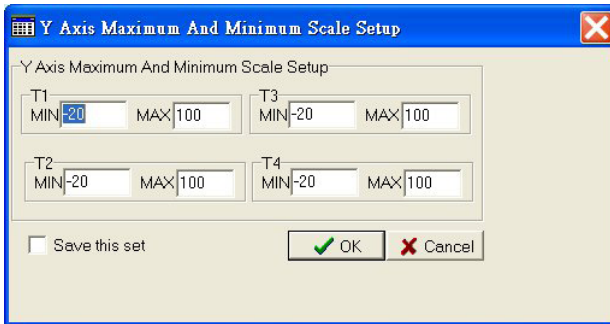

2. Click “Font” to select the font name, style and size for annotations.
3. Click “Y Axis” to customize the maximum and minimum values on the graph.

## Saving Real-Time Data

1. Click the graph window you want to save. The selected graph window will become active.
2. Click “File” and select “Save,” or simply click the disc icon.
3. Enter the file name and file type extension:

File Type	Extension
Graph file. This file type can only be used in SE800024.	*.ghf
Text file	*.txt
EXCEL format file	*.csv

#### 4. Click “Save.”

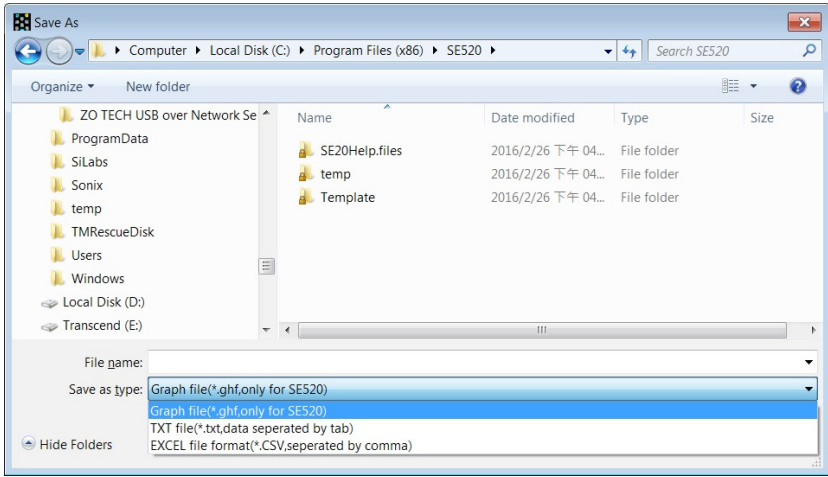

### Printing the Graph

1. Click “File” and select “Print,” or simply click the printer icon.
2. Select the destination printer and click “OK.”

# Downloading Recorded Data

Select “Data Logger” from the main menu bar or click  (the datalogger icon) under the main menu. An indicator shows the loading progress.

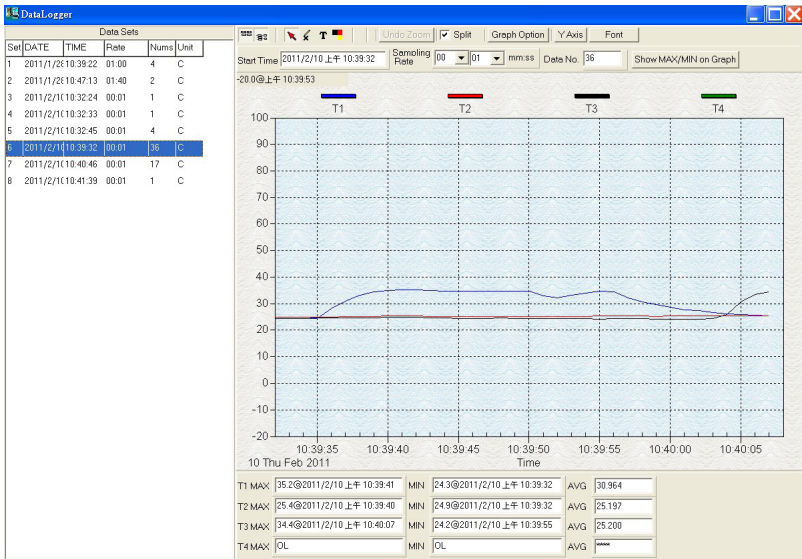
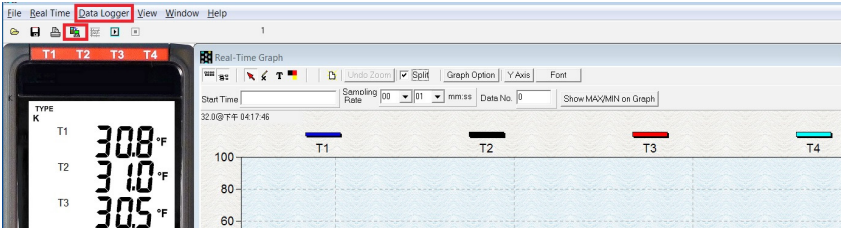

Data Sets										
Set	DATE	TIME	Rate	Nums	Unit	Coupl	T1 Offset	T2 Offset	T3 Offset	T4 Offset
1	2016/2/26	16:25:35	00:01	68	F	K	0.0	0.0	0.0	0.0
2	2016/2/26	16:26:49	00:01	26	F	K	0.0	0.0	0.0	0.0
3	2016/2/26	16:27:33	00:01	19	F	K	0.0	0.0	0.0	0.0
4	2016/2/26	16:28:03	00:01	77	F	K	0.0	0.0	0.0	0.0
5	2016/2/26	16:31:34	00:01	11	F	K	0.0	0.0	0.0	0.0
6	2016/2/26	16:31:49	00:01	24	F	K	0.0	0.0	0.0	0.0
7	2016/2/26	16:32:20	00:01	13	F	K	0.0	0.0	0.0	0.0
8	2016/2/26	16:32:39	00:01	13	F	K	0.0	0.0	0.0	0.0
9	2016/2/26	16:32:59	00:01	7	F	K	0.0	0.0	0.0	0.0

- The left side of the screen will display the number of data sets with detail information for each set.
- The first data set will appear in the graph on the right side.
- Click any data set to graph that set.

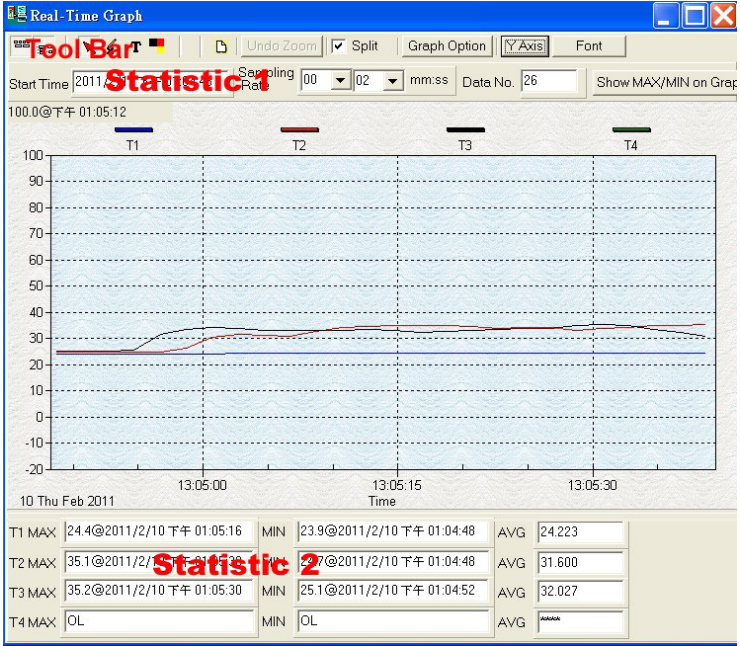

## POWER SUPPLY

### Battery Power

This meter uses four AAA batteries. To install the batteries before first use:

1. Lift the tilt stand on the back of the meter. Unscrew and remove the screw at the bottom of the battery cover.
2. Lift off the battery cover.
3. Insert four new AAA batteries, ensuring correct polarity.
4. Replace the battery cover and reinstall the screw.

Replace the batteries when the low-battery icon blinks on the LCD.

#### Note...

Before replacing the batteries, turn the meter **off** and disconnect the temperature probes.

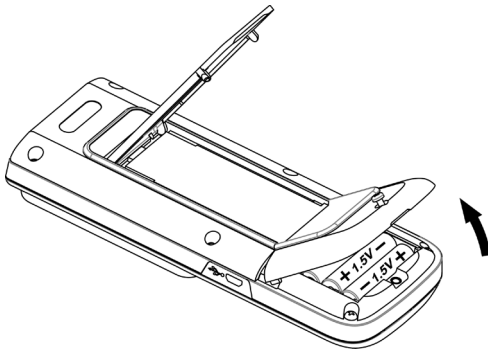

## CARE AND MAINTENANCE

- Periodically wipe the meter with a dry, lint-free antistatic cloth.
- Do not use abrasives, solvents or cleaning agents containing carbon, alcohol or benzenes on the meter.
- Repairs or services not covered in this manual should be performed by qualified personnel only. Please contact Sper Scientific to speak with a technician.

## SPECIFICATIONS

	Range	Resolution	Accuracy (excluding probe error)
<b>Temperature</b>	K -200 to 1372°C -328 to 2501°F	0.1°C < 600°C 1°C ≥ 600°C	at ambient temp. of 18 to 28 °C (64 to 82 °F) ± (0.1% of reading + 0.7 °C) ± (0.1% of reading + 1.4 °F)
	J -200 to 1000°C -328 to 1832°F	0.1°F < 1000°F 1°F ≥ 1000°F	
	E -200 to 750°C -328 to 1382°F		Below -100°C (-148°F) ± (0.4% of reading + 0.7°C) ± (0.4% of reading + 1.4°F)
	T -200 to 400°C -328 to 752°F		
<b>Temperature Coefficient</b>	0.01% of reading + 0.05 °C per °C (<18°C or >28°C)		
<b>Sample Rate</b>	0.5 seconds		
<b>Operating RH%</b>	10 to 90% RH (no condensing)		
<b>Operating Temperature</b>	0 to 50°C 32 to 122°F		
<b>Operating Altitude</b>	≤2000 meters		
<b>Storage RH%</b>	10 to 75% RH		
<b>Storage Temperature</b>	-20 to 60°C -4 to 140°F		
<b>Power Supply</b>	Four 1.5V AAA alkaline or UM-4 batteries		
<b>Battery Power Life</b>	Approximately 100 hrs.		
<b>Dimensions</b>	7.36" x 2.95" x 114" (187 x 75 x 29 mm)		
<b>Weight</b>	10.2 oz (290 g)		

## **WARRANTY**

Sper Scientific warrants this product against defects in materials and workmanship for a period of **five (5) year** from the date of purchase, and agrees to repair or replace any defective unit without charge. If your model has since been discontinued, an equivalent Sper Scientific product will be substituted if available. This warranty does not cover probes, batteries, battery leakage, or damage resulting from accident, tampering, misuse, or abuse of the product. Opening the meter to expose its electronics will break the waterproof seal and void the warranty. To obtain warranty service, ship the unit postage prepaid to:

**SPER SCIENTIFIC LTD.**

8281 E. Evans Rd., Suite #103  
Scottsdale, AZ 85260  
(480) 948-4448

The defective unit must be accompanied by a description of the problem and your return address. Register your product online at [www.sperwarranty.com](http://www.sperwarranty.com) within 10 days of purchase.

